



Ravaglioli

COMPANY WITH QUALITY MANAGEMENT
SYSTEM CERTIFIED BY DNV
= ISO 9001:2008 =

BIKE & BIKE



KP

1394

1396

G

7240.

BIKE

G

1.111

2.116



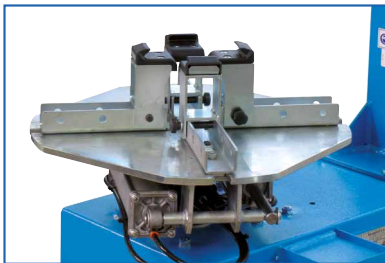
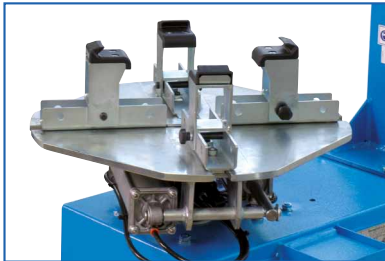
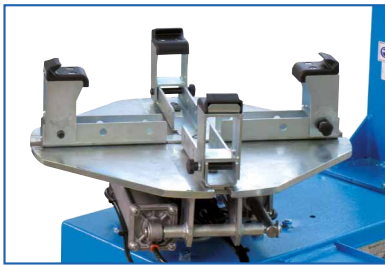

G7240.BIKE

Smontagomme specialmente allestiti per lo smontaggio di ruote da moto.

Tyre changers especially designed to handle motorcycle wheels.

Reifenmontiergeräte speziell ausgestattet für die Montage von Motorrädern.

Démonte-pneus avec équipement spécial pour les roues moto.

Desmontadoras fabricadas especialmente para ruedas de moto.

G7240.BIKE

Bloccaggio esterno
External clamping
Aussengespannt
Blocage extérieur
Bloqueo exterior

5" - 24"



G1.111

Macchina compatta a lancio manuale. Misurazione con lancio unico a bassa velocità di rotazione.

Compact hand spin machine. Single launch measurement with low rotation speed.

Kompaktmaschine mit manuellem Anwurf. Einzelner Messvorgang mit niedriger Drehgeschwindigkeit.

Équilibruse à lancement manuel. Mesure avec un seul lancement à basse vitesse de rotation.

Equilibradora de lanzamiento manual. Medición con un unico lanzamiento a baja velocidad de rotación.

G1.111
+GAR181
+GAR181A1

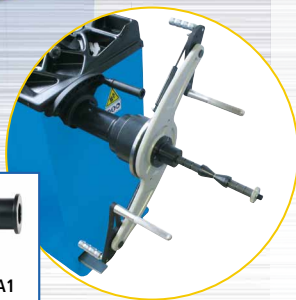

GAR181A1

GAR181 > 14 mm

G2.116

Equilibratrice elettronica computerizzata con elevate prestazioni di rapidità e precisione. Lancio unico a motore e arresto automatico a fine ciclo.

Electronic computerised wheel balancer with high performances in terms of rapidity and accuracy. Single motor driven launch with automatic stop at the end of the cycle.

Computer gesteuerte Wuchtmaschine für ein präzises und schnelles Wuchten. Einzelner Messvorgang mit automatischer Abbremsung am Ende, Motor getrieben.

Équilibruse électronique à microprocesseur avec prestations de rapidité et précision. Un seul lancement par moteur et arrêt automatique en fin de cycle.

Equilibradora electronica con altas prestaciones de rapidez y precisión. Lanzamiento unico de motor y bloqueo automatico al final del ciclo.

Options GAR 181



Options GAR 181+GAR 191





KP1394 + S1394 A1



KP1394P + S1394 A1

Easy
Wheel
Service

KP1394 - KP1394P / kg 400

Sollevatore a pantografo con pompa idraulica a pedale (KP1394) o con pompa oleopneumatica (KP1394P). Altezza di sollevamento ottimale di 800 mm.

Pantograph lift with foot-operated hydraulic pump (KP1394) or with air-hydraulic pump (KP1394P). Lifting height of 800mm.

Parallelogrammbühne mit hydraulischer Fusspumpe (KP1394) oder mit lufthydraulischer Pumpe. Optimale Hubhöhe von 800 mm.

Élévateurs à pantographe avec pompe hydraulique à pédale (KP1394) ou pompe hydropneumatique (KP1394P). Hauteur de levage optimale de 800 mm.

Elevador de pantografo con bomba hidraulica de pedal (KP1394) o con bomba hidroneumatica (KP1394P). Altura de elevación optimal de 800 mm.

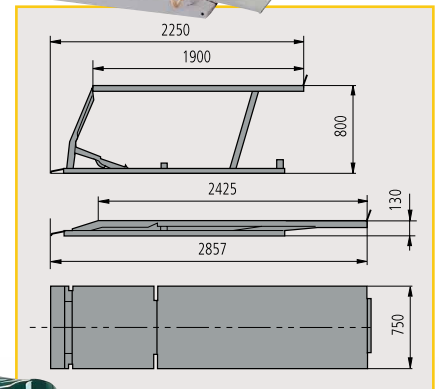

OPTIONS

S 1394A1



S 1394A2



KP1396P - KP1396E / kg 600

Sollevatore a forbice con pompa oleopneumatica (KP1396P) o con centralina elettro-idraulica (KP1396E). Notevole altezza di sollevamento di 1.000 mm.

Scissors lift with air-hydraulic pump (KP1396P) or with electro-hydraulic control box (KP1396E). Great lifting height of 1000 mm.

Scherenhebebühne mit lufthydraulischer Pumpe (KP1396P) oder elektrohydraulisch (KP1396E). Bemerkenswerte Hubhöhe 1.000 mm.

Élévateurs à ciseau avec pompe hydropneumatique (KP1396P) ou pompe électro-hydraulique (KP1396E). Hauteur de levage importante de 1.000 mm.

Elevador de pantografo con bomba hidroneumatica (KP1396P) o con bomba electrohidraulica (KP1396E). Notable altura de elevación de 1000 mm.

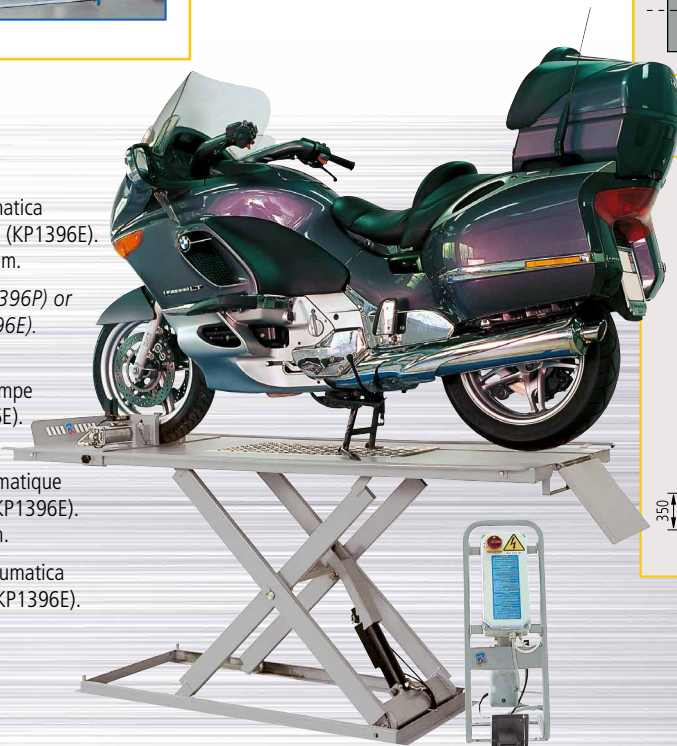

KP 1396E + S 1394 A2

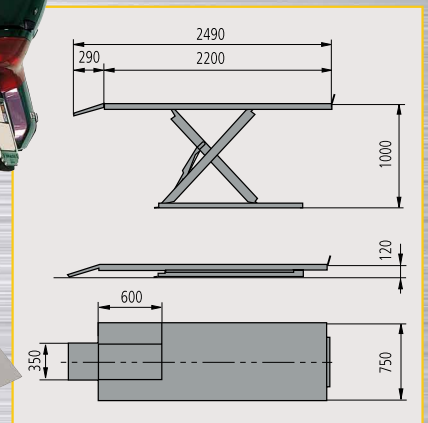

KP 1396P + S 1394 A1



Easy
Wheel
Service



KP1394T - KP1394TP / kg 400

Sollevatori con pedana di larghezza maggiorata (1000 mm) per il sollevamento di moto e macchine da giardinaggio.

Wide platform (1000 mm) to lift garden machinery.

Bühnen mit breiter Aufnahmefläche (1000 mm) zum Heben von Motorrädern und Gartengeräte.

Élévateurs avec plateforme plus large (1.000 mm) pour le levage de motos et motoculteurs.

Elevador con plataforma de ancho mayor (1.000 mm.) para la elevación de motos y maquinas de jardin.

KP1394T Sollevatore con pompa idraulica a pedale	KP1394TP Sollevatore con pompa oleopneumatica
<i>Lift with foot-operated hydraulic pump</i>	<i>Lift with air-hydraulic pump</i>
Bühne mit hydraulischer Fusspumpe	Bühne mit lufthydraulischer Pumpe
<i>Élévateur avec pompe hydraulique à pédale</i>	<i>Élévateur avec pompe hydropneumatique</i>
Elevador con bomba hidraulica de pedal	Elevador con bomba hidroneumatica

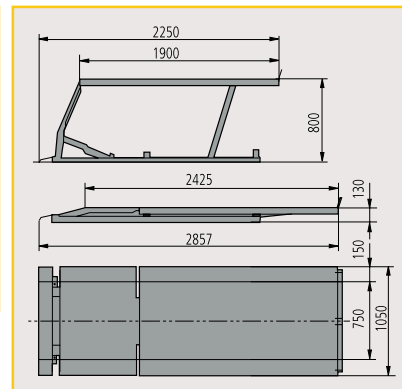

KP1396TP - KP1396TE / kg 600

Sollevatori con pedana di larghezza maggiorata (1450 mm) per il sollevamento di tricicli e quadricicli/microvetture.

Very wide platform (1450 mm) to lift 3-wheel vehicles and micro-cars.

Bühnen mit breiter Aufnahmefläche (1450 mm) zum Heben von Dreirädern und Kleinfahrzeugen.

Élévateurs avec plateforme extra-large (1450 mm) pour levage de triporteurs et microvoitures.

Elevador con plataforma de ancho mayor (1450 mm.) para la elevación de triciclos/ micro-turismos.

KP1396TP Sollevatore con pompa oleopneumatica	KP1396TE Sollevatore con pompa elettroidraulica
<i>Scissors lift with air-hydraulic pump</i>	<i>Scissors lift with electro-hydraulic pump</i>
Bühne mit lufthydraulischer Pumpe	Bühne mit elektrohydraulischer Pumpe
<i>Élévateurs avec pompe hydropneumatique</i>	<i>Élévateurs avec pompe électro-hydraulique</i>
Elevador con bomba hidroneumatica	Elevador con bomba electrohidraulica

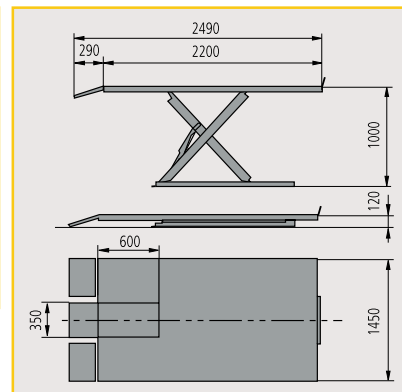

BIKE TEST LANE



Ravaglioli S.p.A.

40037 Sasso Marconi
Fraz. Pontecchio M.
P.O.B. 1690 - Bologna - Italia
Tel. +39 - 051 - 6781511
Fax +39 - 051 - 846349
rav@ravaglioli.com
www.ravaglioli.com

RAV France

6, Rue Longue Raie
ZAC de la Tremblaie
91220 Le Plessis Pâté
Tel. 01.60.86.88.16
Fax 01.60.86.82.04
rav@ravfrance.fr

Ravaglioli Deutschland

Kirchenpoint 22
85354 Freising
Tel. 08165-646956
Fax 08165-646958
info@ravaglioli.de

RAV Equipment UK LTD

Prince Albert House
20 King Street
Maidenhead, SL6 1DT
Tel. 020-76286832
Fax 020-76286833
ravuk@ravaglioli.com

RAV en Belgique

Nederlandstalig
Tel. 0498-162016
Fax 016-781025
Zone Francophone
Tel. 0498-163016
Fax +32 78 055 030

RAV Equipos España

Avenida Europa 17
Pol. Ind. de Constanti
Tarragona 43120
Tel. 977 524525
Fax 977 524532
ravequipos@ravaglioli.e.telefonica.net

DRN30U (2)

Le caratteristiche tecniche e gli allestimenti presentati in questo prospetto possono subire variazioni. Le immagini riprodotte non sono vincolanti.
Technical data and composition presented in this catalogue may vary. Pictures reproduced are only indicative.
Die techn. Daten und die Ausrüstungen, die in diesem Prospekt enthalten sind, können Änderungen erfahren. Deshalb sind die Abbildungen unverbindlich.
Les caractéristiques techniques et les compositions présentées dans ce prospectus peuvent subir des variations. Les images reproduites n'ont qu'une valeur indicative.
Las características técnicas y las composiciones ilustradas en este folleto pueden sufrir variaciones. Las imágenes propuestas son solamente indicativas.

